



USER'S GUIDE

Installation, Operation, Maintenance Instructions



V-Tork Series

Point Level Switch for Liquids

Introduction	5
Models	6
Models and Dimensions	7
Wiring Diagram	8
V-Tork Status Guide	10
Installation	12
Handling	13
Technical Specifications	14
Ordering Information	20
Trouble Shooting	21
Terms & Conditions	22

V-Tork Series: Point Level Switch



Sitron's V-Tork Series point level switch for liquids vibrate at a fixed pre-defined resonant frequency. When the tuning fork is submerged in the medium the frequency at which the switch is vibrating, changes. This change is detected by the unit's electronics and is converted into a switch output (either relay or PNP/NPN depending on the model).

The red LED in the housing stays blinking when the V-Tork is in contact with the product. The same light stays on continuously when there is no contact with the product, giving a positive indication at all times that the V-Tork is working.

All models are made with 316 Stainless Steel and are available with Halar® or epoxy coatings and hygienic fittings for sanitary applications. Standard versions can operate at temperatures up to 80°C (176°F) and higher temperature versions can operate at temperatures up to 100°C (212°F). All models (except the mini-versions) have adjustable time delay adjustment of 1, 5, 10 or 20 seconds and also have a Wet/Dry selection for both High and Low level application requirements.

Features

- Unaffected by variations in density, conductivity or dielectric constant
- Unaffected by foam, tank agitation or vibration
- Available in Threaded, Sanitary and Flanged connections
- Available with customized length options to best suit your application
- All 316SS body and wetted parts, Halar® coating when necessary
- Adjustable response time (from 1 to 20 seconds)
- Relay and Transistor outputs available

Models

MVTK-AC/DC

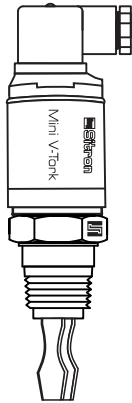

**VTK-R / VTK-DC
N1 HOUSING**

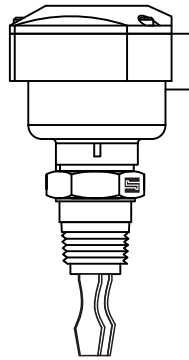

**VTK-R
G1 HOUSING**

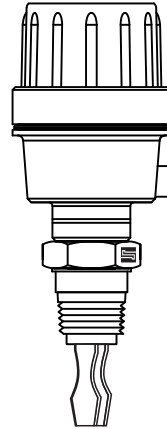

**VTK-R
G2 HOUSING**

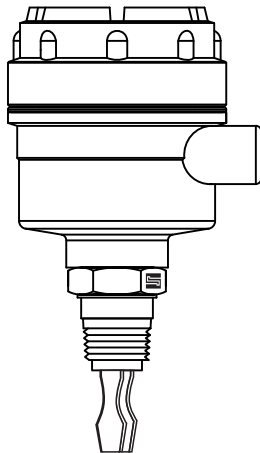

**VTK-R
GX HOUSING
EXd**

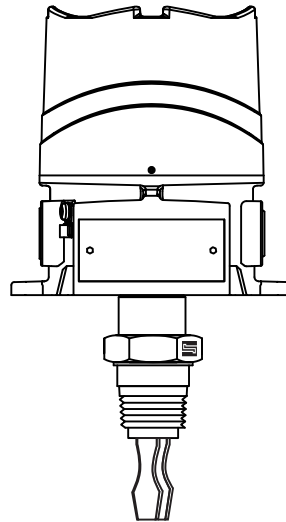

Models and Dimensions

Mounting Options for V-Tork

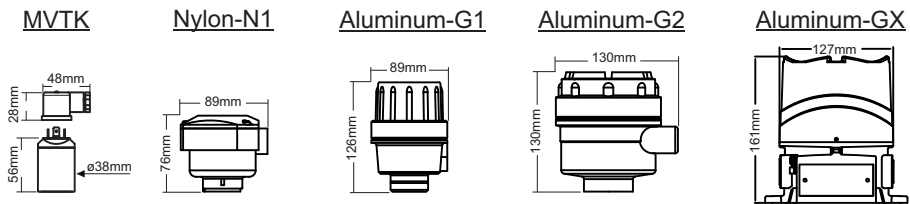

Extended Necks for High Temperature

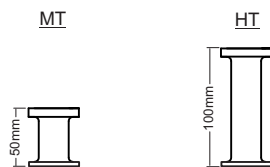

Extended necks for medium temperature (up to 80°C) and high temperature (up to 100°C)

Insertion Length

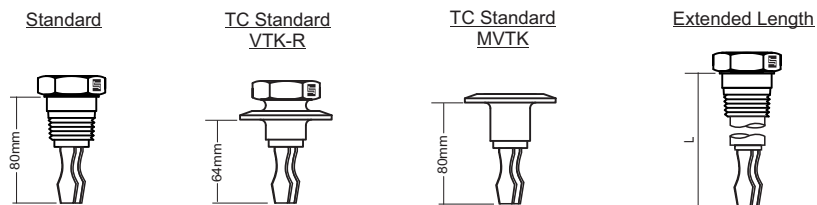

Process Connections

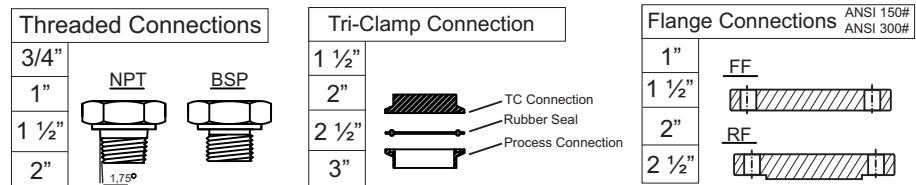

Wiring Diagram

VTK-DC N1 Housing

- 1 - Power Supply (+)
- 2 - Power Supply (-)
- 3 - PNP/NPN Output or +24v/0v (Max 500mA)
- 4 - Ground

VTK-DC with M12 connector

- 1 - Power Supply (+)
- 2 - Power Supply (-)
- 3 - PNP/NPN Output or +24v/0v (Max 500mA)
- 4 - Ground

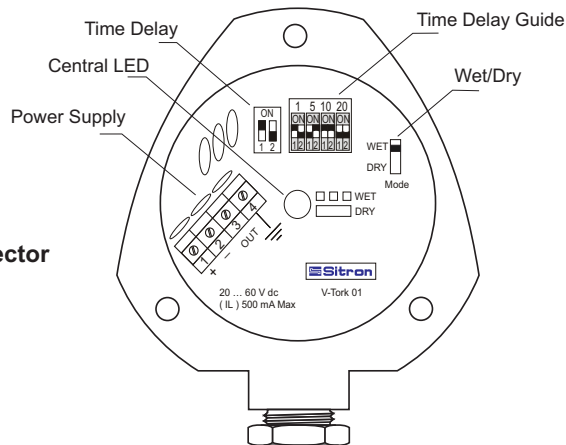

VTK-R Universal Power Supply N1 Housing

- 1 - Supply (L) } AC (~)
- 2 - Supply (-) } DC (==)
- 3 - Supply (+) } DC (==)
- 4 - NO Contact
- 5 - Common
- 6 - NC Contact

M12 Connector

- 1 - Supply (L) or (+)
- 2 - Supply (-)
- 3 - NO Contact
- 4 - NC Contact
- 5 - Common

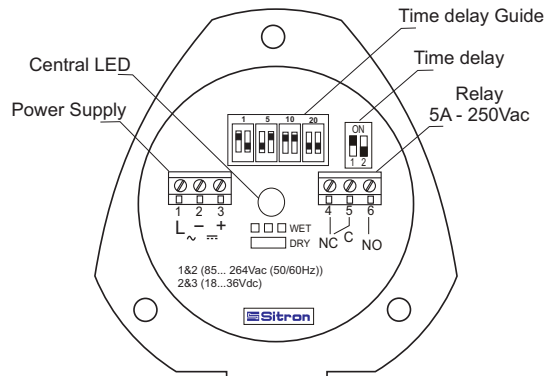

Time Delay Guide

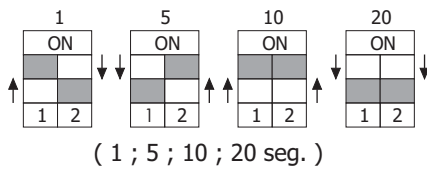

The different key positions indicate the time delay in seconds.

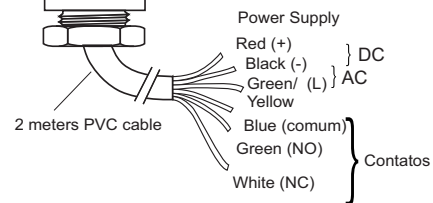

Wiring Diagram

VTK-R Universal Power Supply G1/G2 Housing

- 1 - Power Supply (L) } AC (~)
- 2 - Power Supply (-) } AC (~)
- 3 - Power Supply (+) } DC (≡)
- 4 - NC Contact
- 5 - Common
- 6 - NO Contact

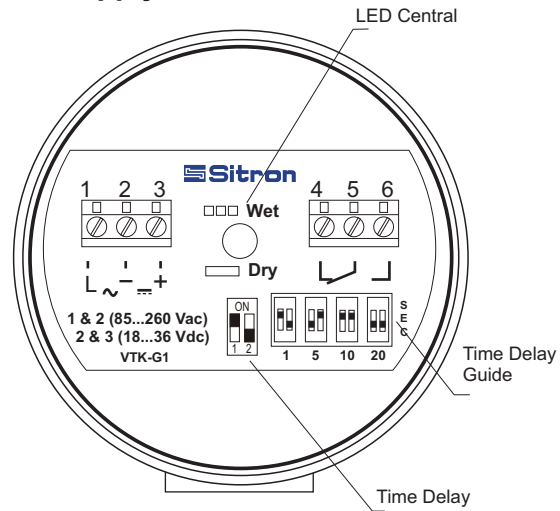

- 1 - Power Supply (L) } AC (~)
- 2 - Power Supply (-) } AC (~)
- 3 - Power Supply (+) } DC (≡)
- 4 - NO Contact
- 5 - NO Common
- 6 - NC Contact
- 7 - NC common

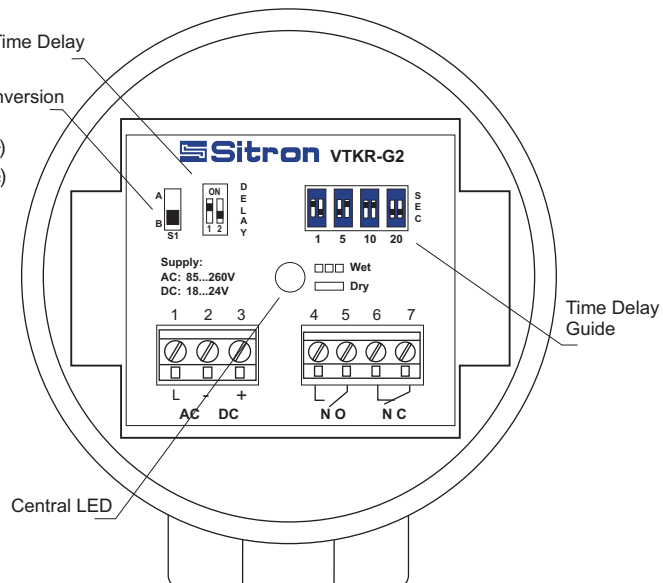

Wiring Diagram

GX - Housing

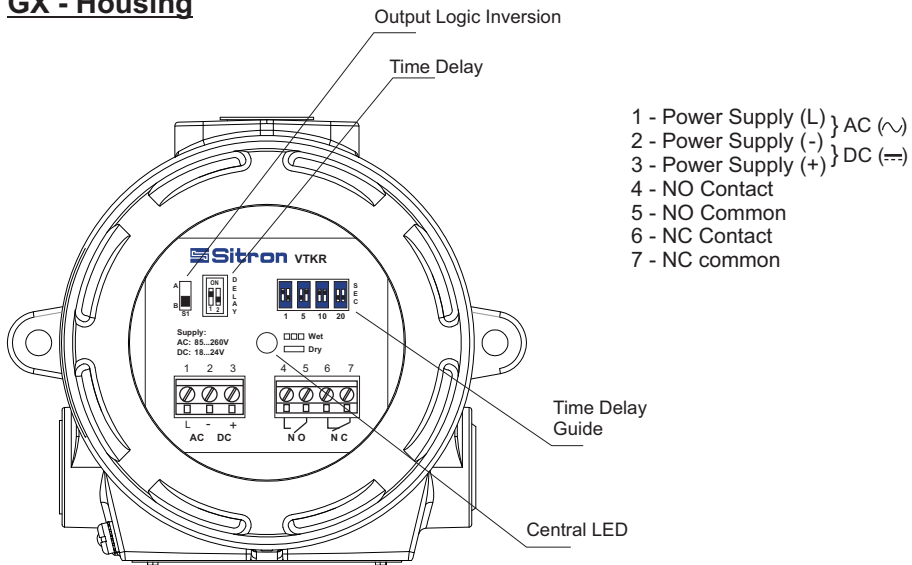





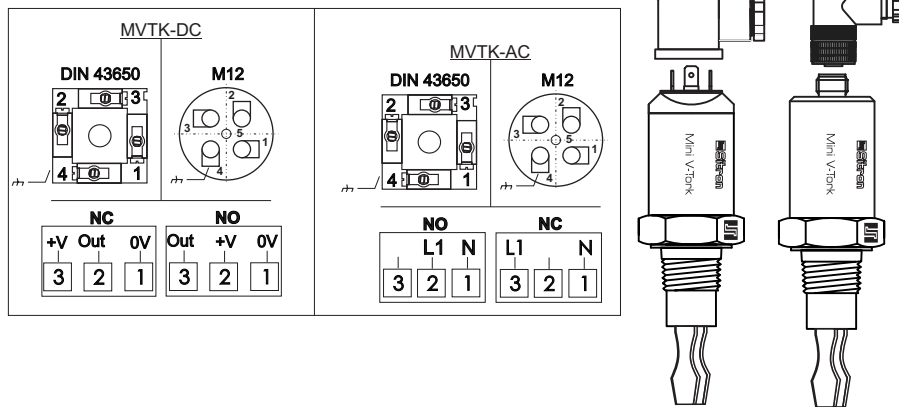

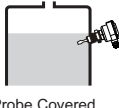

MVTK

⚠ To avoid burning the unit, make sure that the load has been installed in series with the MVTK before powering it up.

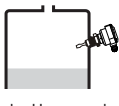

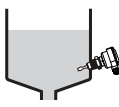
V-Tork Status Guide

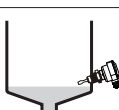
For V-Tork / DC

Switch Position	Level	Out	Central LED
WET  Maximum fail-safe	 Probe Covered		WET (Blink)
	 Probe Uncovered		DRY (On)
DRY  Minimum fail-safe	 Probe Covered		WET (Blink)
	 Probe Uncovered		DRY (On)

For V-Tork / R (Universal Power Supply)

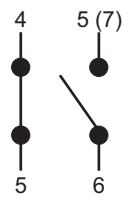
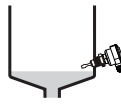
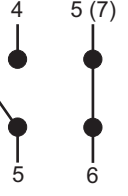
Level	NO - NC	Central LED
 Probe Covered		WET (Blink)
 Probe Uncovered		DRY (On)

MVTK Status Guide

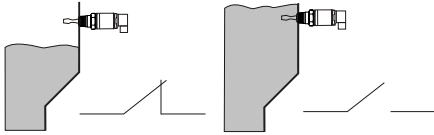
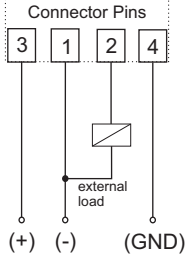
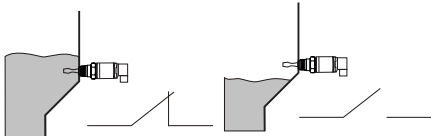
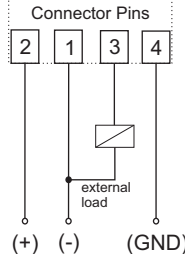
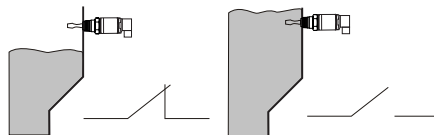
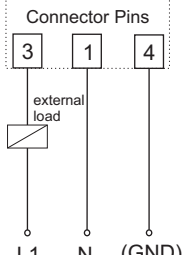
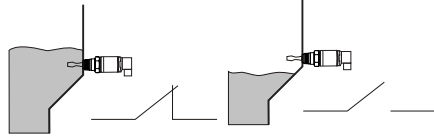
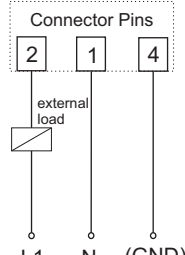
<p><u>MVTK / DC (Operating Mode NC)</u></p> 	<p>Connector Pins</p>  <p>(+) (-) (GND)</p>
<p><u>MVTK / DC (Operating Mode NO)</u></p> 	<p>Connector Pins</p>  <p>(+) (-) (GND)</p>
<p><u>MVTK / AC (Operating Mode NC)</u></p> 	<p>Connector Pins</p>  <p>L1 N (GND)</p>
<p><u>MVTK / AC (Operating Mode NO)</u></p> 	<p>Connector Pins</p>  <p>L1 N (GND)</p>

Installation

Confirm that the wire connections are correct and that the available power supply is compatible with the V-Tork unit.

Verify that the operating pressure and temperature of the process corresponds to the operating parameters of the V-Tork unit.

The V-Tork can be installed at any angle of the pipe or vessel to detect the presence of liquids.

Verify that the forks are inserted into the medium until the proper point within the vessel and that they stay clear from the inside walls (Fig. 1 and 2).

Ensure that the conduit is facing downward and makes a U-turn on the bottom of the cable to avoid moisture from entering the housing enclosure (Fig.3).

For proper installation of the V-Tork use the mark as a reference for correctly positioning the forks. It is recommended that the correct orientation be used to avoid build up between the forks (Fig. 4).

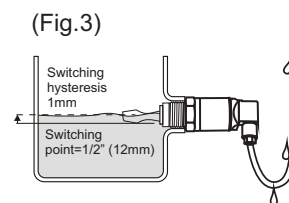
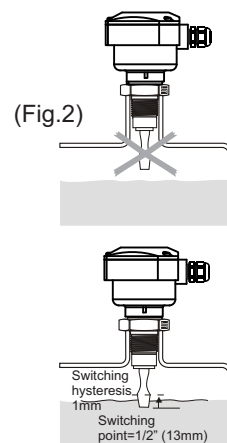
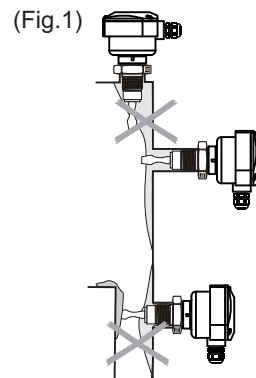
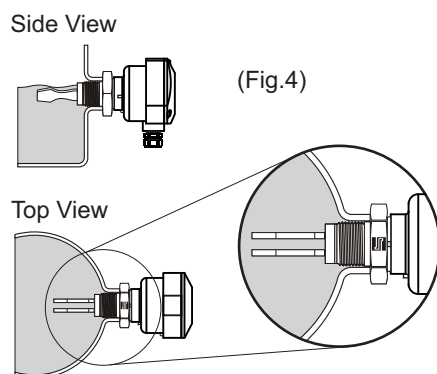

Handling

Seal the thread with Teflon tape before installation (Fig. 1).

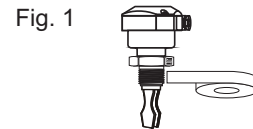

Do not thread the unit into the vessel, or turn it, by the housing (Fig. 2).

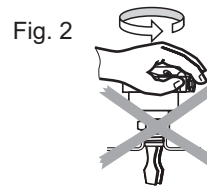

Use the correct tools during the installation of the V-Tork (Fig. 3).

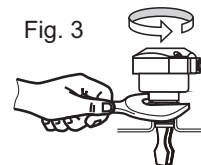

The V-Tork should not be dropped or suffer any impact or fall that could damage the electronics, coating or the forks of the probe (Fig. 4 and 5).

Periodic visual inspection of the V-Tork is required to check for corrosion or deposit build-up. If deposits are found, clean the sensor to ensure optimum performance.

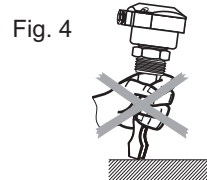

When cleaning the Forks use a soft brush to ensure that the coating or polishing is not damaged or scratched.

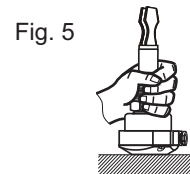

Do not alter or bend the shape of the forks (Fig. 6).

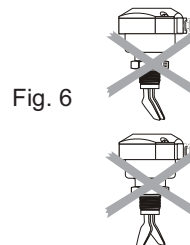

Technical Specifications

VTK-DC

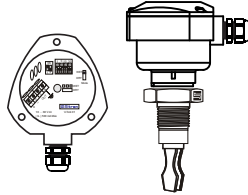

N1 Enclosure

Application	Level switch for liquids
Operating Voltage	20...60 Vdc
Current Consumption	+/- 3mA
Output	PNP (3 wires)
Medium Viscosity	0.5...5000 cSt
Accuracy	0.1%
Repeatability	< 0.5mm
Time Delay	1 to 20 seconds (adjustable)
Switching Point	13mm from tip
Load Current (Max)	500mA
Enclosure Material	Glass filled nylon
Electrical Connection	½" NPT, M12 Connector or Cable Gland
Process Connection	¾" to 1 ½" BSP, NPT or sanitary
Wetted Material	316 Stainless Steel
Operating Temperature	-14 to 176° F (-10 to 80°C)
Max Pressure	725 PSI (50 Bar)
Class Protection	IP 65 IEC

Technical Specifications

VTK-R

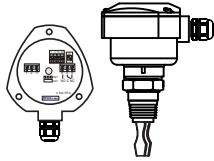

N1 Enclosure

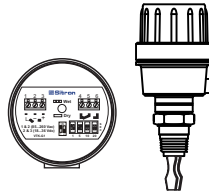

G1 Enclosure

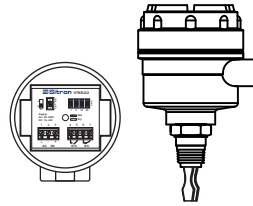

G2 Enclosure

Application	Level switch for liquids
Operating Voltage	18...36 Vdc 85...264 Vac (50/60Hz)
Current Consumption	DC < 6mA AC < 10mA
Output	Relay (SPDT) N1, G1 (1NO+1NC) G2
Medium Viscosity	0.5...5000 cSt
Accuracy	0.1%
Repeatability	< 0.5mm
Time Delay	1 to 20 seconds (adjustable)
Switching Point	13mm from tip
Load Current Relay (Max)	5A (250 Vac)
Enclosure Material	Glass filled nylon, N1
Electrical Connection	½" NPT, M12 Connector or Cable Gland
Process Connection	¾" to 1 ½" BSP, NPT or sanitary
Wetted Material	316 Stainless Steel
Operating Temperature	-14 to 176° F (-10 to 80°C)
Max Pressure	725 PSI (50 Bar)
Class Protection	N1 Housing: IP 65 IEC G1 / G2 Housing: IP66 IEC (NEMA 4 / 4X)

Technical Specifications

MVTK-DC

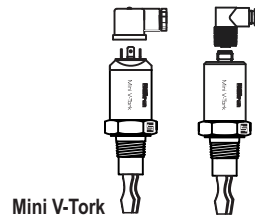

Application	Level switch for liquids
Operating Voltage	20...60 Vdc
Current Consumption	+/- 3mA
Output	PNP (3 Wires)
Medium Viscosity	0.5...5000 cSt
Accuracy	0.1%
Repeatability	< 0.5mm
Time Delay	1 sec.
Switching Point	13mm from tip
Load Current (Max)	500mA
Enclosure Material	316 Stainless Steel
Electrical Connection	Plug DIN 43650
Process Connection	3/4" to 1 1/2" BSP, NPT or sanitary
Wetted Material	316 Stainless Steel
Operating Temperature	-14 to 212° F (-10 to 100°C)
Max Pressure	725 PSI (50 Bar)
Class Protection	DIN 43650 connector IP 65 IEC M12 connector IP67 (NEMA 6)

Technical Specifications

MVTK-AC

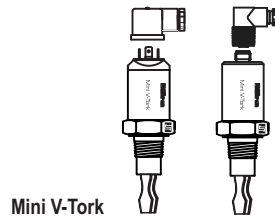

Application	Level switch for liquids
Operating Voltage	85...264 Vac
Current Consumption	+/- 3mA
Output	Direct Load Switching (2 Wire)
Medium Viscosity	0.5...5000 cSt
Accuracy	0.1%
Repeatability	< 0.5mm
Time Delay	1 sec.
Switching Point	13mm from tip
Load Current (Max)	100mA
Enclosure Material	316 Stainless Steel
Electrical Connection	Plug DIN 43650
Process Connection	3/4" to 1 1/2" BSP, NPT or sanitary
Wetted Material	316 Stainless Steel
Operating Temperature	-14 to 212° F (-10 to 100°C)
Max Pressure	725 PSI (50 Bar)
Class Protection	DIN 43650 connector IP 65 IEC M12 connector IP67 (NEMA 6)

VTK-R

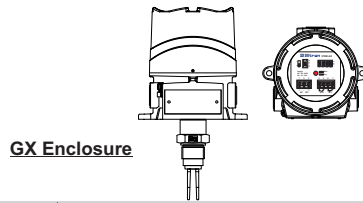

Application	Level switch for liquids
Operating Voltage	18...36 Vdc 85...260 Vac (50/60Hz)
Current Consumption	DC < 6mA AC < 10mA
Output	Relay (SPDT) (1NO+1NC)
Medium Viscosity	0.5...5000 cSt
Accuracy	0.1%
Repeatability	< 0.5mm
Time Delay	1 to 20 seconds (adjustable)
Switching Point	13mm from tip
Load Current Relay (Max)	5A (250 Vac)
Enclosure Material	Aluminum
Electrical Connection	2x 3/4" NPT
Process Connection	BSP, NPT or Sanitary
Wetted Material	316 Stainless Steel
Operating Temperature	-14 to 176° F (-10 to 80°C)
Max Pressure	725 PSI (50 Bar)
Class Protection	IP 66
Housing Certification	ATEX, DEMKO 07 ATEX 0622294, 0539 II 2 G EX d IIC Gb / 0539 II 2 D Ex tb IIIC Db IECE / IECx UL 08.0005 / Ex d IIC Gb / Ex tb IIIC Db

Ordering Information

MODEL	
VTK-DC	Enclosure - 20...60Vdc Power Supply - Output PNP (3 Wire)
VTK-R	Enclosure - Universal Power Supply - Output Relay (1SPDT)
MVTK-DC	No enclosure - 20...60Vdc Power Supply - Output PNP (3 Wire)
MVTK-AC	No enclosure - 85...264Vac Power Supply - Output 2 Wire

SIZE	
4	3/4"
5	1"
6	1 1/2"
7	2"
9	3"
Q	4"
X	OTHER

PROCESS CONNECTION TYPE	
B	BSP
N	NPT
D	FLANGE ANSI 150# - Carbon Steel Painted
E	FLANGE ANSI 150# - 316 SS
G	FLANGE ANSI 300# - Carbon Steel Painted
H	FLANGE ANSI 300# - 316 SS
K	FLANGE ANSI 150# - 304 SS
L	FLANGE ANSI 300# - 304 SS
T	TRI-CLAMP
X	OTHER - SPECIFY

COATING	
S	NONE
H	HALAR [®] Coated
E	EPOXY Coated
P	Polished
X	OTHER - SPECIFY

INSERTION LENGTH	
L80	L=3 1/8" (80mm) - Standard
L64	L=64mm - Standard (Sanitary connection)
L	SPECIFY

HOUSING	
SC	No enclosure
N1	Small Nylon
NE	N1 Encapsulated
G1	Small Aluminum
G2	Large Aluminum
GX	Aluminum (EX d)

ELECTRICAL CONNECTION	
1	1/2" BSP
2	PC 1/2" BSP
6	1/2" NPT
7	PC 1/2" NPT
D	DIN Connector 18 (43650)
M	M12 Connector
X	OTHER - SPECIFY

ACCESSORIES	
A	Clamp
B	Sanitary Nipple - 1"BSP
F	O'ring seal for clamp
S	Sanitary Nipple - TC Connections
MT	Medium Temp - 50mm 316SS Neck (up to 100C)
HT	High Temp - 100mm 316SS Neck (up to 120C)
0	NONE

Trouble Shooting

Fault	Case	Solution
Does not switch	The central LED is not on	Verify the Power Supply
	The LED flashes 3 times/sec.	Internal failure
	The LED flashes once every 2 seconds	Internal failure
	The LED flashes once every 4 seconds	High current load or short circuit. Check the installation.
	The Fork is encrusted with build-up	Clean the forks
Incorrect switching	Dry = on Wet = on	Properly configure the key switch
	Fast switching	Select a longer time delay

Terms & Conditions

Sitron's TERMS & CONDITIONS

Design: Sitron reserves the right to make any alterations or changes necessary to improve the Products, correct defects or to make the Products safer, without prior notice or consent by Buyer.

Pricing: All stipulated amounts shall be in US dollars and all prices quoted are valid for thirty (30) days from date of offer, unless otherwise stated.

Safety and Instructions: The Buyer ensures that it and all its representatives and agents will observe all safety and technical instructions in Sitron's operating manuals, catalogs or other directions or instructions (either written or verbal).

Delivery and Freight: All goods are sold FOB point of shipment, Brasil. Transportation to the destination is the Buyer's responsibility and Buyer alone shall bear the cost of freight, optional or other shipping requirements, and or insurance. Sitron shall not be liable for loss or damage to the Products after said Products are delivered to or received by the shipper/carrier, and all risk of damage or loss shall immediately pass to Buyer.

Receiving, unloading and storing of Products will be the responsibility of the Buyer.

Buyer also accepts that courier may choose to return Products to Sitron if any local taxes or duties are not paid by Buyer at point of delivery. Buyer must make any and all claims for corrections or deductions within ten days of the delivery of the Products.

Shipment Delays: Sitron has no control over the length of time shipments may be held at customs, etc. For this reason, Sitron commits only to a "shipment date", not a "delivery date". Buyer shall not hold Sitron liable for claims resulting from delay in shipment except in cases where these terms are accepted in writing by Sitron. Acceptance of delivery of Products by Buyer shall constitute a waiver of all claims for delay.

Partial Deliveries: While Sitron strives to deliver all orders on time and complete, Sitron reserves the right to make partial deliveries when necessary.

Changes: Any changes initiated by the Buyer which affects the products specifications; quantities ordered; delivery schedule; method of shipment or packing; or delivery location, must be made in writing and signed by both parties.

In this case, Sitron reserves the right to adjust the pricing and or delivery of the order, which will be agreed to by both parties before further work is performed on the order. Any such requests will be priced according to the scope of changes and the status of the current order. Customer must sign and return or acknowledge approval of drawings along with any Purchase Order. If approval drawings are not returned with order, the delivery date may be held or pushed back until Customer has acknowledged approval.

Cancellation: Any cancellation of the Contract by the Buyer shall be effective only if made in writing and accepted, in writing by the Sitron. In such a case, Sitron is entitled to reasonable cancellation charges including but not limited to labor, material and other related expenses.

Terms & Conditions

Termination Fee Schedule:

Order entered but not released for manufacturing	10%
Order in any stage of production	75%
Order complete and ready for shipment	100%

Warranty: Sitron warrants its product against manufacturing defects in material and workmanship, when installed in applications approved by Sitron, for a period of one year from the date of original shipment, unless otherwise stated in writing by Sitron.

Sitron is not responsible for damage to Sitron's Products or other equipment or products because of improper installation or misapplication of the Products by Buyer. Installation or startup of Sitron's equipment must be performed under the guidelines set forth in Sitron's instruction manuals, wiring diagrams, etc., or performed under the direct supervision of Sitron's field technicians or Sitron's authorized Sales Representatives, in order to be covered by Sitron's warranty.

Sitron shall be under no liability in respect to any defect from fair wear and tear, willful damage, negligence, abnormal working conditions, failure to follow Sitron's instructions (whether written or verbal), misuse, modification or alteration or attempted repair of the Goods without Sitron's approval.

Sitron shall not be liable under the above warranty (or any other warranty, condition or guarantee) if the total price for the Products or the payment of Services rendered has not been paid by the due date for payment.

The Buyer must make all tools, resources or personnel available to help Sitron to diagnose the defect without any back charge. In absence of Buyer's cooperation in this regard, there shall be no liability under the above Warranty.

Sitron's liability under this warranty shall be limited to repair or replacement at Sitron's option of such defective Products, FOB factory, upon proof of defect satisfactory to Sitron. Warranty does not include transport.

Return Goods: No goods may be returned without Sitron's permission and an RMA number. Sitron assumes no responsibility for return shipments made without permission. In issuing credit for such shipments, Sitron reserves the right to charge a restocking fee dependent on Sitron's ability to recondition and resell the returned equipment.

Insurance: The responsibility for insuring the Goods after the risk in them has passed to the Buyer shall be that of the Buyer.

Confidential Information: All drawings, specifications, and technical information provided by either Buyer or Sitron shall be treated as confidential and shall not be disclosed to anyone other than those who require it as part of the fulfillment of the order. Buyer agrees that the designs and/or any other related material provided are and remain Sitron's exclusive property and that the Buyer acquires no right, title or interest to this intellectual property, whether in whole or in part.

Errors: Sitron reserves the right to correct all typographical or clerical errors or omissions, in its prices or specifications.



VTORK_03_2017

Sitron - Brasil
R. Baronesa de Itu, 83
São Paulo - SP - 01231-001
T: (5511) 3825-2111
F: (5511) 3825-2171

Sitron - USA
1800 Prime Place
Hauppauge, NY 11788
PH: 516-935-8001
FX: 800-516-1656

www.sitron.com
BRASIL: vendas@sitron.com
USA / Other Countries: info@sitron.com