

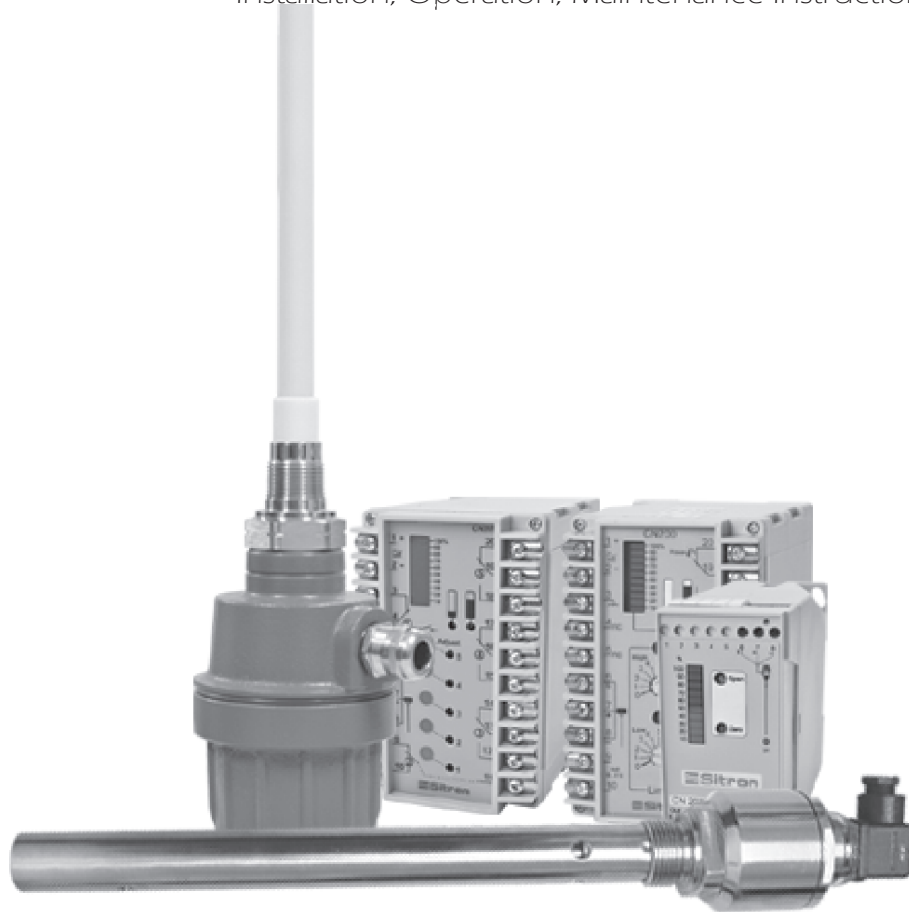

USER'S GUIDE

Installation, Operation, Maintenance Instructions



SC 120 & CN Controller

Capacitive Level Transmitter

Contents

Introduction	3
Models & Dimensions	4
Wiring Diagram	6
Mounting Note	13
Installation	15
Calibration	19
Handling	22
Technical Specifications	23
Trouble Shooting	28
Ordering Information	29
Terms & Conditions	30

SC120 & Controller CN



The SC120 Series Capacitance Level Measurement System is designed to measure and control the level in most industrial applications. The SC120 probe works in conjunction with the CN Series of level controllers. The SC120 is available in 316SS with optional PTFE tubing or Halar coatings (required for conductive or aggressive mediums). The CN controller with an integrated bar graph display gives the operator an overview of the level within the vessel. With 4...20mA output signal and up to 5 Relay switch outputs, this system provides a complete level control solution for most applications.

How it works:

A capacitor consists of the probe's rod as one plate and the metallic wall of the vessel (or a secondary reference rod or sheath) as the other plate. As the medium rises and displaces the empty space within the vessel, the dielectric constant around the probe changes. This change is recorded and converted into either a relay switch output or a 4...20mA output signal which is proportional to the level within the vessel. By using this principle, the SC120 + CN Series can be applied in a wide range of products such as most liquids, powders, pastes and granular mediums.

Features

- Used in a wide range of application/industries
- Accurate and reliable measurement.
- No moving parts - Rugged construction.
- Can operate at high temperatures and pressure.
- Functions on conductive as well as non-conductive medias.

Models & Dimensions

Mounting Options

Extended Necks for Higher Temperatures



Note: Medium Temperature (up to 120°C) and High Temperature (up to 150°C)

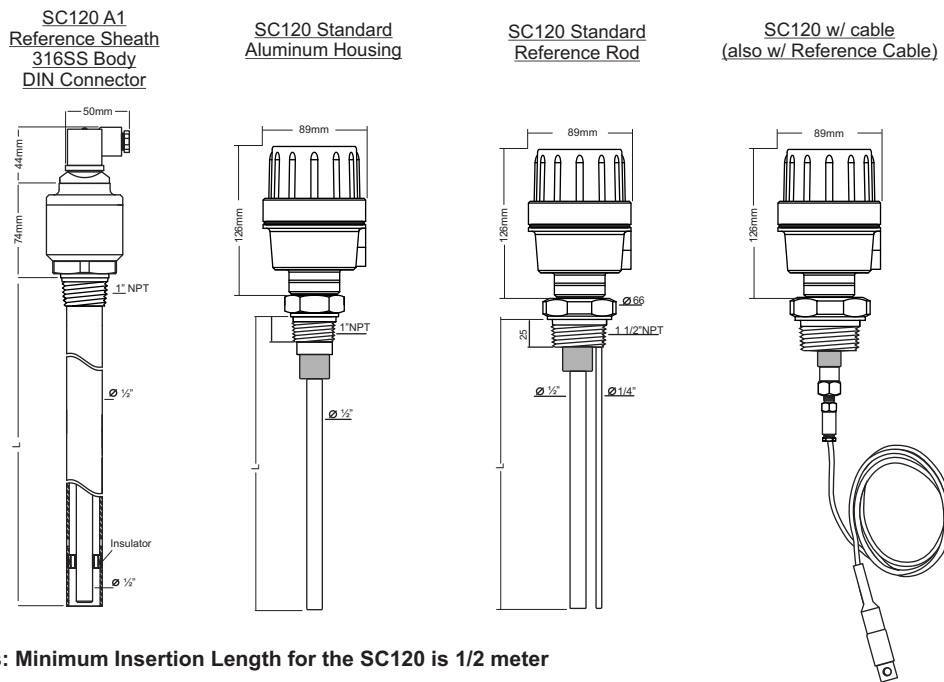

Obs: Minimum Insertion Length for the SC120 is 1/2 meter

Process Connection

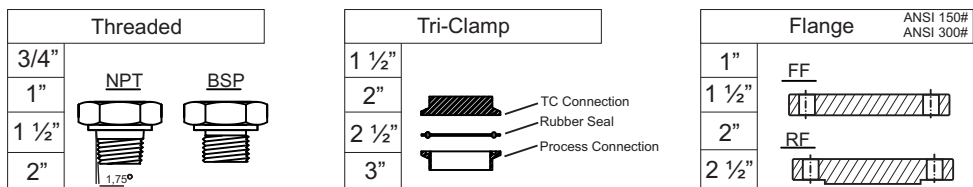

Models & Dimensions

Controllers:

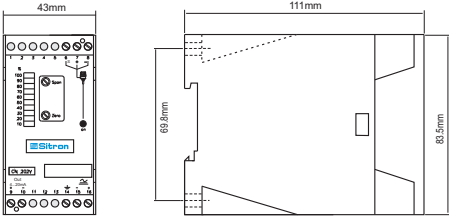
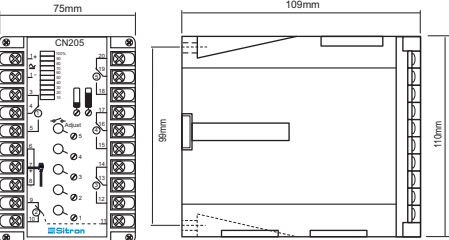
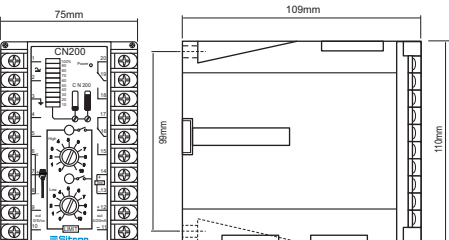
CN202	Features
	<ul style="list-style-type: none"> - Output 4...20mA with Zero and Span adjustment; - Bargraph with scale of 0 to 100% of Level Indication; - Available in 24Vdc or 85...264 Vac Power Supply;
CN205	Features
	<ul style="list-style-type: none"> - Bargraph Level Indicator from 0 to 100%; - 5 output Relay with individual set-point adjustment; - Available in 24Vdc or 85...264 Vac Power Supply;
CN200	Features
	<ul style="list-style-type: none"> - Bargraph Level Indicator from 0 to 100%; - Output 4...20mA or (0...5 Vdc optional); with Zero and Span adjustment; - 2 Outputs Relay (Low and High) with individual set-point Adjustment; - Available in 24Vdc or 85...264Vac Power Supply;

Wiring Diagram

SC120:

The SC120 Series works in conjunction with the CN Series Controllers. Do Not Power the Probe with another Brand of Controllers.

ALUMINUM HOUSING

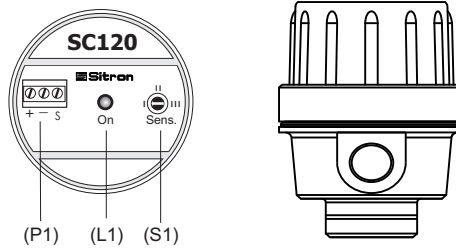

L1- Led Status: Connected
 S1- Sensitivity Control
 P1- Power Supply and Output Signal.

DIN CONNECTOR 43650

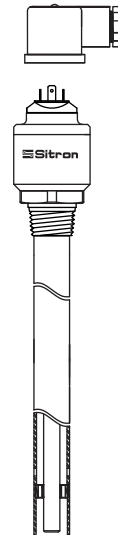
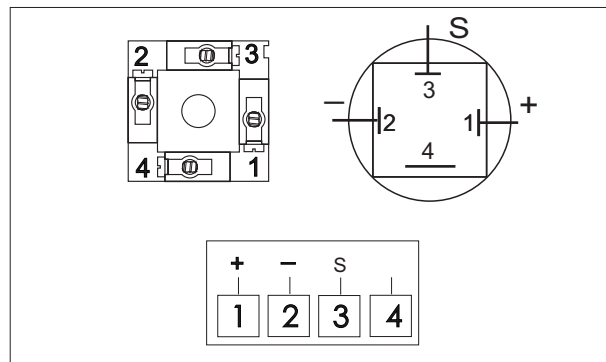

Wiring Diagram

CN 202

- A- Bargraph Level Indication.
- B- Adjust Zero (low level).
- C- Adjust Span (high level).

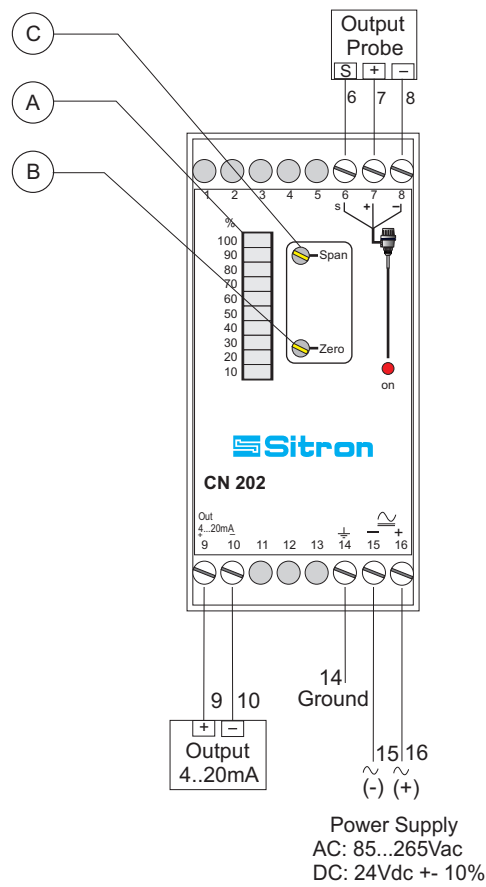

Wiring Diagram

CN205

- A- Bargraph Level Indication.
- B- Led Set-point Indication (1,2,3,4,5).
- C- Adjust Set-point (1,2,3,4,5).
- D- Adjust Zero (low level).
- E- Adjust Span (high level).

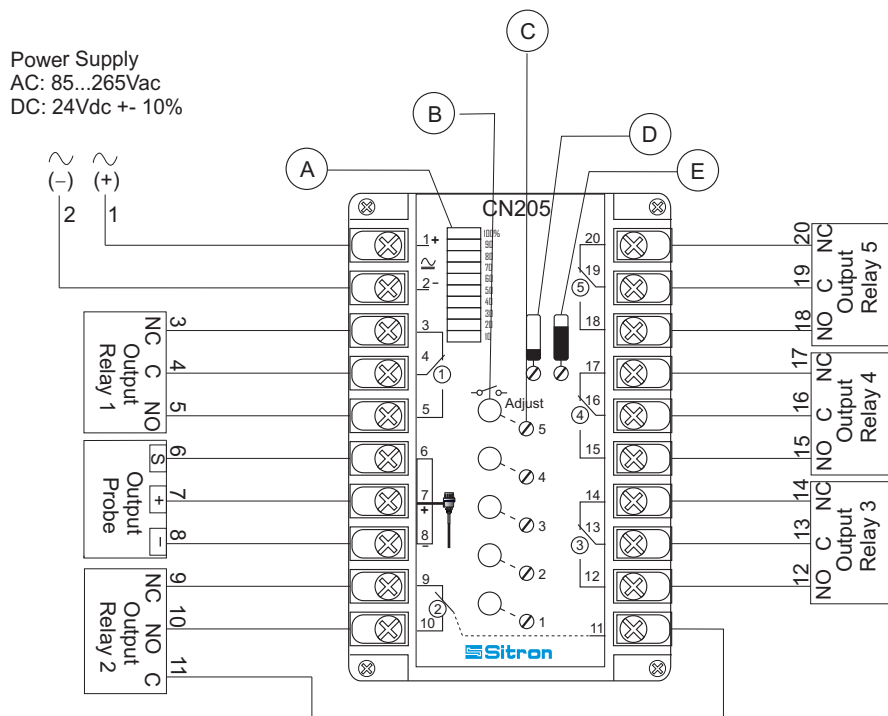

Wiring Diagram

CN202

- A- Bargraph Level Indication.
- B- Led Set-point Indication (Low & High).
- C- Adjust Zero (low level)..
- D- Adjust Span (high level)
- E- Adjust Set-point.

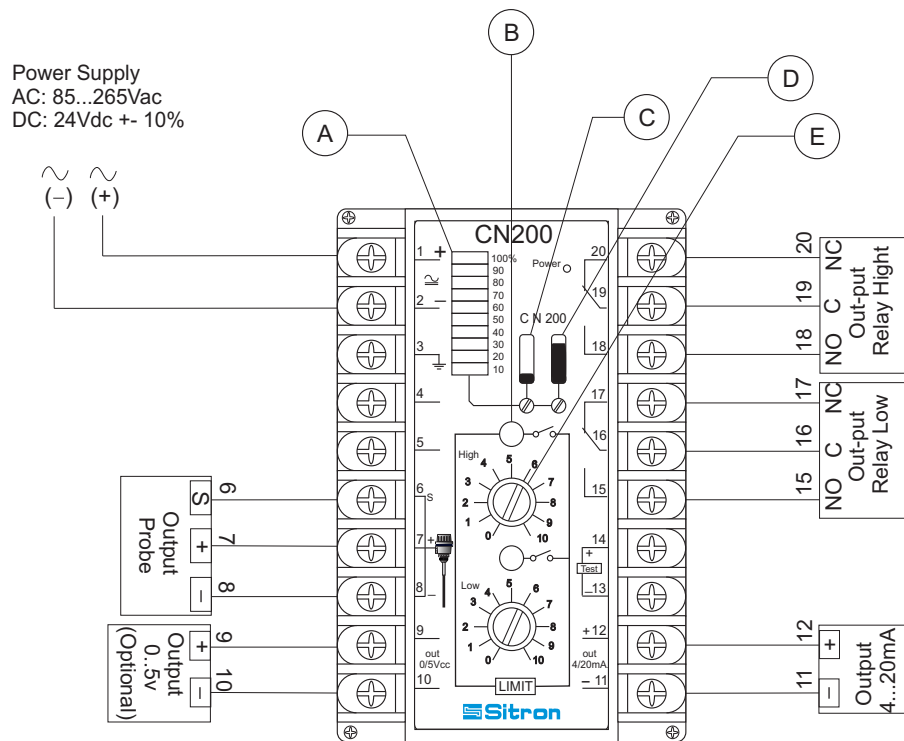

SC120 & CN202 Wiring Diagram

Important: Before connecting the equipment, make sure it is properly powered as show on ID tag.

SC120 A1 & CN202

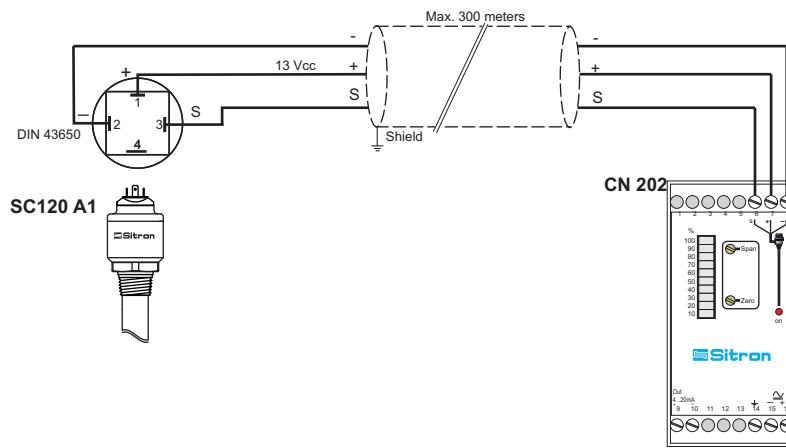

SC120 G1 & CN202

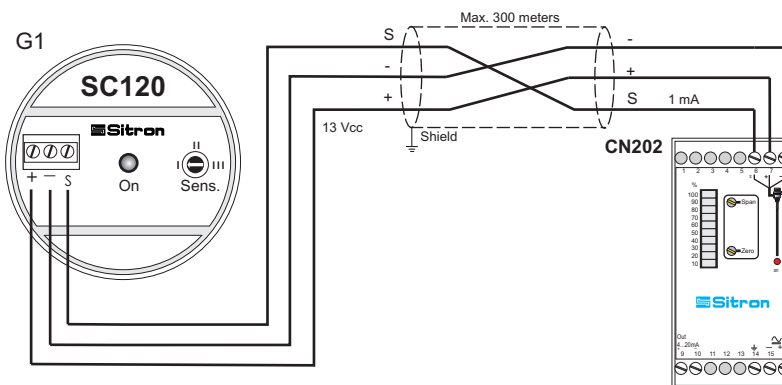

SC120 & CN205 Wiring Diagram

Important: Before connecting the equipment, make sure it is properly powered as show on ID tag.

SC120 A1 & CN205

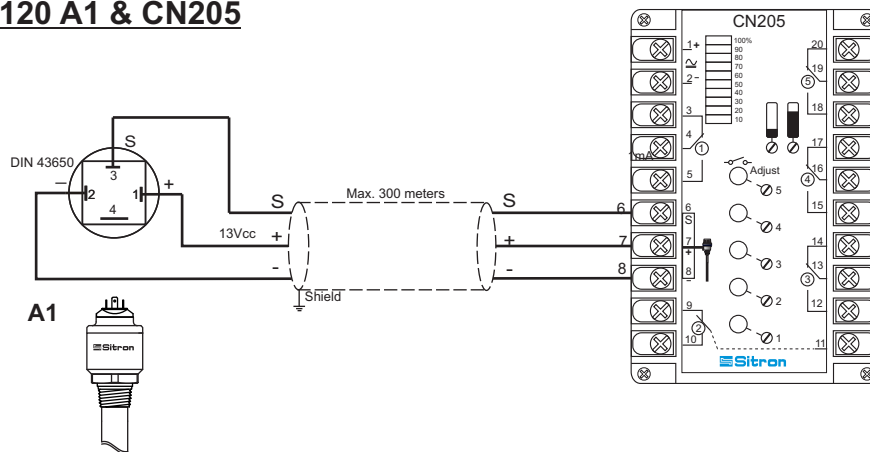

SC120 G1 & CN205

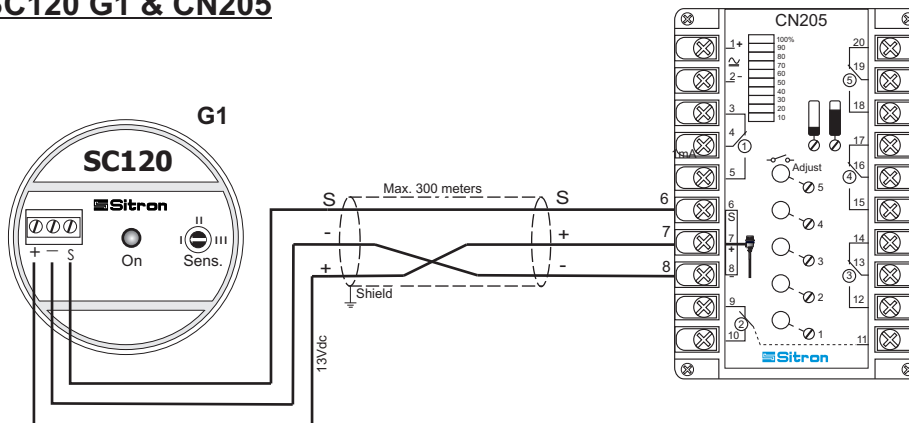

SC120 & CN200 Wiring Diagram

Important: Before connecting the equipments, make sure it is properly powered as show on ID tag.

SC120 A1 & CN200

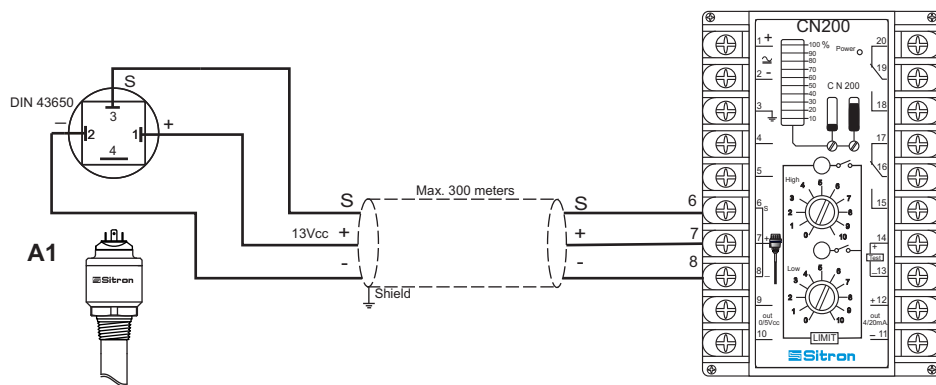

SC120 G1 & CN200

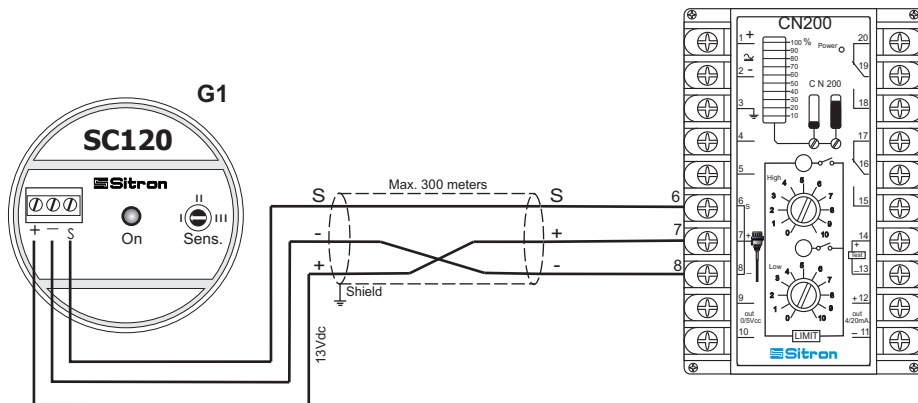

Mounting Notes

Mediums that are conductive will cause a short circuit between a bare stainless steel probe and the tank wall. For that reason we recommend the use of Halar or other types of insulating coatings on the rod's surface (Fig. 1)

Material build-up also affects the accuracy of RF capacitive measurements, and therefore additional adjustment to the probe's sensitivity is recommended in applications where build-up is a concern (Fig. 2)

Housings must also be compatible with the requirements for wash-down, wet, and/or dusty environments. Hazardous environments may require the housing to be certified. In addition, the active probe might need to be intrinsically safe or have an intrinsic safety barrier.

The electronic circuitry of the probe performs several functions such as rectifying and filtering the incoming power, generating the radio frequency signal, measuring the changes in current flow, analog signal generators and display meters. The circuitry is provided with potentiometer adjustments for setting sensitivity that is located in the housing of the probe. These adjustments give an added level of fine-tuning which enable the user to control the probe's sensitivity with greater accuracy (Fig. 2).

Variation in current input (power supply) to the probe will affect the output. Therefore, a stable power supply should be available.

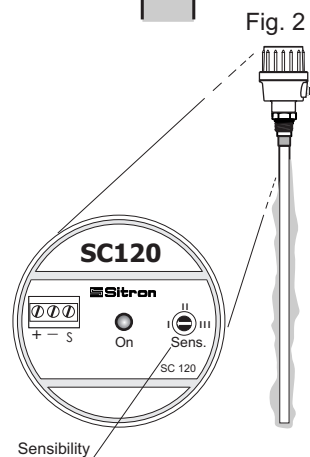
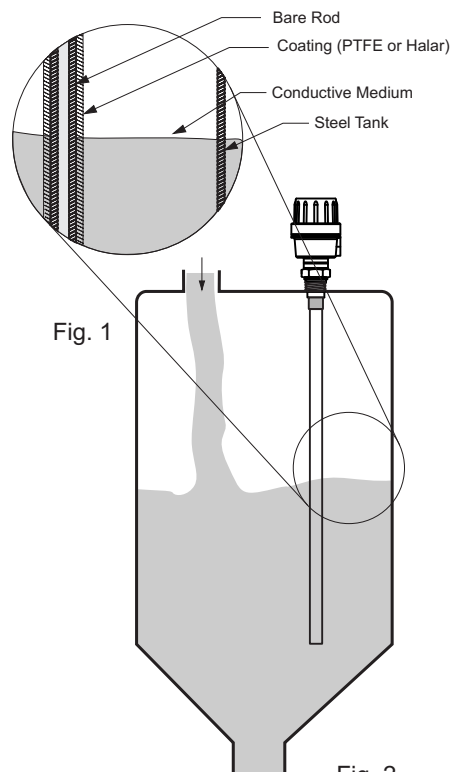

Mounting Notes

When making connections between the controller and the probe use reliable cables and make sure they are grounded.
Shielded cables prevent interference improving and protecting against false measurements.

Do not install the controller in harsh environments and humidity.
Respect class protection, working temperature and protect the same from rain and excessive heat.
A stable Power Supply prevents damage and equipment malfunction.

Controller Mounting

Panel mounting with the protection cover

A- DIN rail (35mm)

B- Screws (6mm)

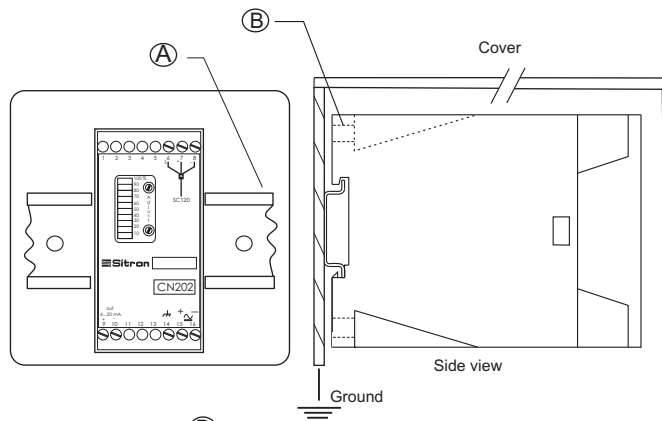

Panel mounting with the protection cover

C- DIN rail (35mm)

D- Screws (3,5mm)

Note: CN205 and CN200 can be installed vertically or horizontally.

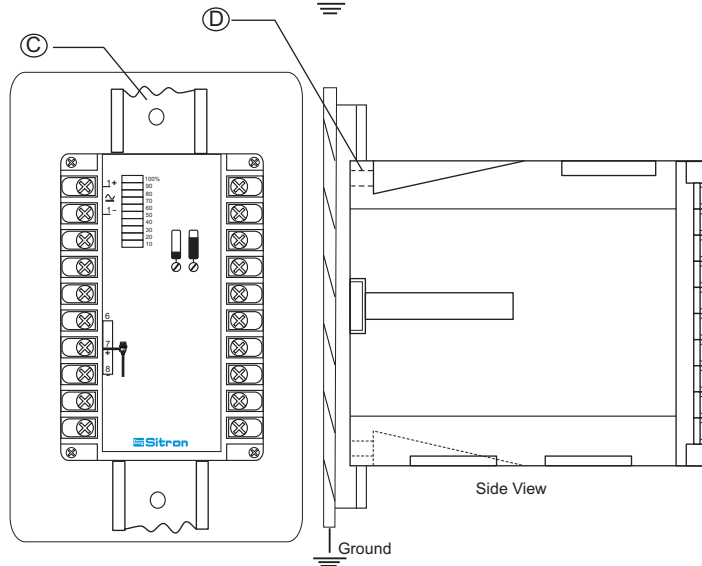

Installation

When installing the probe either directly to the tank, or utilizing a connection, the capacitance probe should be mounted on the top of the tank, never on the side or angle, so that the rod stays parallel to the tank wall (Fig. 1 correct Fig. 2 Incorrect).

The mounting location of the probe should stay clear away from the point where the medium enters, this will avoid false reading from the sensor while being filled (Fig. 1 correct Fig. 2 Incorrect).

The recommended distance of installation of the probe from the internal wall is a minimum of 500mm, and from the tip of the rod to the bottom of the tank is 100mm, this will prevent a false signal and possible build up between the wall and probe (Fig. 1 correct Fig. 2 Incorrect).

Note: For high pressure and explosion proof applications, care should be taken when tightening the connection as achieving a proper seal is very important.

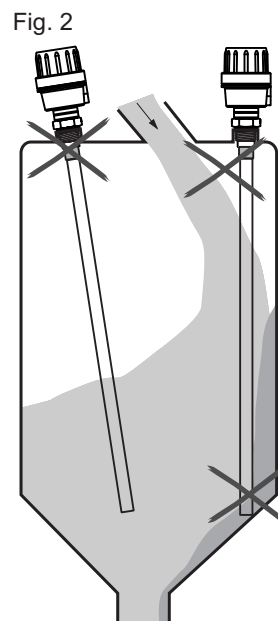
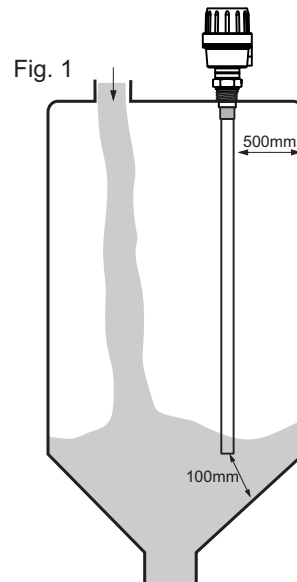

Installation

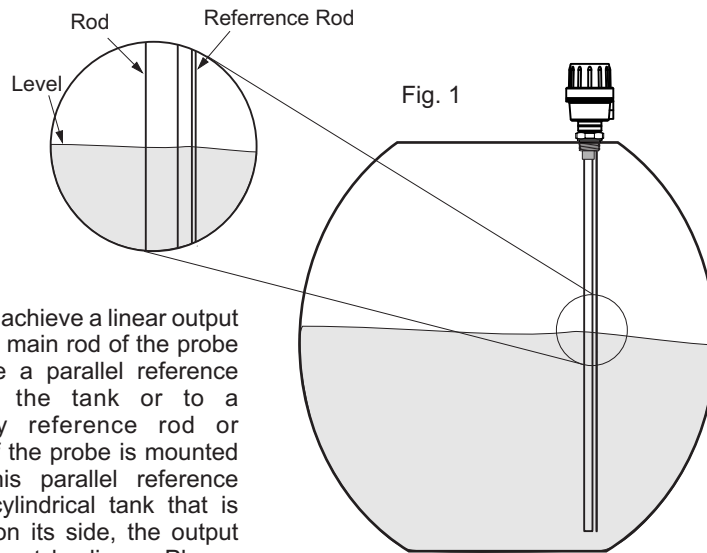

In order to achieve a linear output signal, the main rod of the probe must have a parallel reference either to the tank or to a secondary reference rod or sheath. If the probe is mounted without this parallel reference within a cylindrical tank that is mounted on its side, the output signal will not be linear. Please consult one of our applications engineers if you have further questions (Fig.1 correct/Fig.2 incorrect).

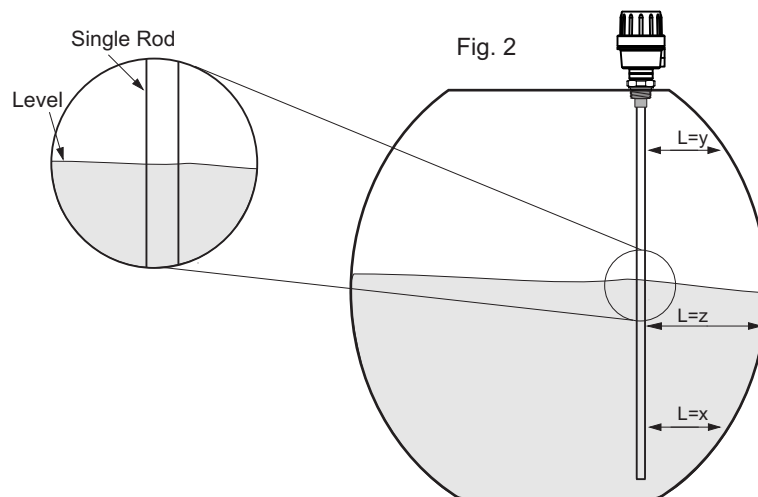

Installation

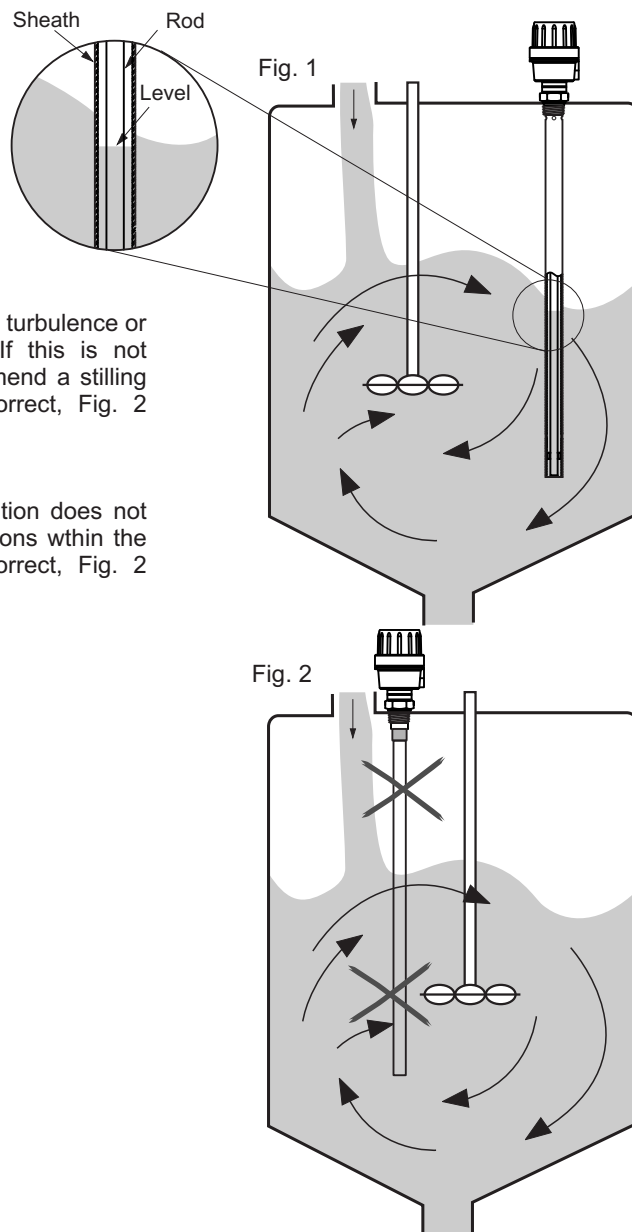

The tank must be free from turbulence or vortices throughout use. If this is not possible we highly recommend a stilling well or sheath (Fig. 1 correct, Fig. 2 incorrect).

Ensure that mounting position does not interfere with any obstructions within the vessel or tank (Fig. 1 correct, Fig. 2 incorrect).

Installation

When installing the SC120 with cable and reference be sure that they are well connected to the bottom of the tank and that it has no slack. (Fig. 1 correct Fig. 2 Incorrect).

The mounting location of the probe should stay clear away from the point where the medium enters, this will avoid false reading from the sensor while being filled (Fig. 1 correct Fig. 2 Incorrect).

The recommended distance of installation of the probe from the internal wall is a minimum of 500mm, and from the tip of the pendulum to the bottom of the tank is 100mm, this will prevent a false signal and possible build up between the wall and probe (Fig. 1 correct Fig. 2 Incorrect).

If the cable is secure to the bottom of the vessel it must be isolated and the vessel is steel it must be isolated so that it does not create a short circuit.

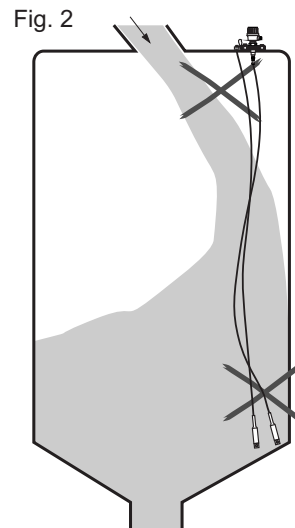
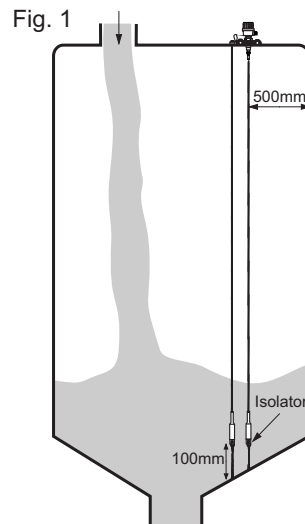

CN Controller Calibration

Adjustment 4mA.

It is recommended that a multimeter be connected according to the figure(fig.4) to monitor the current value during the calibration. Prior to calibration it is recommended that both potentiometers are reset. Turn both potentiometers counter-clockwise or approximately 5 turns (Fig. 1). The bargraph is calibrate according to the signal (4mA-0% and 20mA- 100%).

Note: For the controller CN200 the calibration is done orienting yourself to bargraph level indicator (0% to 100%).

1) Drain the tank to minimum level (Zero% or 4mA).

2) Select the Sens. switch 1,2,3 located in the probe Unit SC120G1. It is recommended to begin with Sens. switch 1 (Fig. 2).

3) Use the Zero potentiometer to set the current value for the actual level to 4mA or 0%. Turn the potentiometer clockwise to increase current. Turn the potentiometer counter-clockwise to decrease current (If the adjustment wasn't possible, alter the Sens. position and try in adjust the minimum value (4mA) through the Zero Potentiometer)(Fig.3).

Fig.1

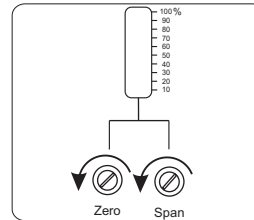

Fig.2

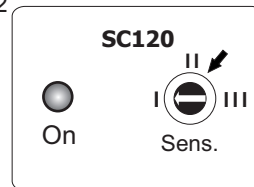

Fig.3

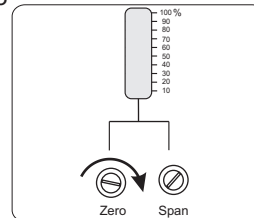
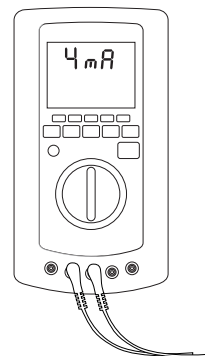

Fig.4



CN Controller Calibration

Adjustment 20mA.

After calibrating the minimum value (4mA or 0%), fill up the tank to maximum level (100% - level).

4) Use the Span potentiometer to set the current value for the actual level to 20mA or 100%. Turn the potentiometer clockwise to increase current. Turn the potentiometer counter-clockwise to decrease current (Fig.5).

5) If the current is lower than 20mA or 100% after fully turning the Span Potentiometer clockwise, it is necessary to increase the sensitivity by selecting the next level of the switch (Sens.). If the current still remains lower than 20mA or 100%, continue on to the next level until achieve 20mA.

6) With the 20mA or 100% signal adjusted it is best to re-adjust the Zero. Drain the tank back down to the starting level and re-adjust (if necessary) the minimum level to 4mA or 0% one more time. After this stage, set-up is complete.

Fig.5

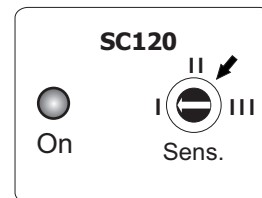
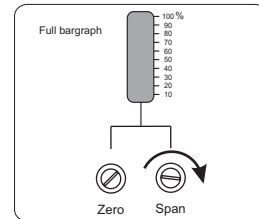
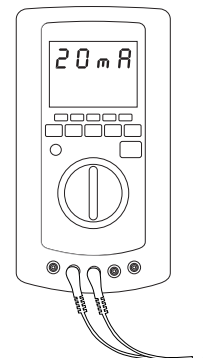

Fig.4



CN200 & CN205 Calibration

CN200 Set-Point adjustment.

After completed the calibration, it is necessary to be done to adjust the set-point outputs of the case is used.

CN200 controller has 2 outputs Relay (SPDT),with indication LOW and HIGH. To adjust, make sure the outputs are not actuated (statement made by the LED's), if necessary turn the potentiometers clockwise (fig.1).

- 1) Low Level Control.
Fill the tank to the first point , then turn the potentiometer (Low) counter-clockwise until the LED indicator turn-on.
- 2) High Level Control.
Fill the tank to the second point, then turn the potentiometer (High) counter-clockwise until the LED indication turn-on.

With two adjusted points, confirm the points draining and filling the tank until the set-points, re-adjust if necessary.

Fig.1

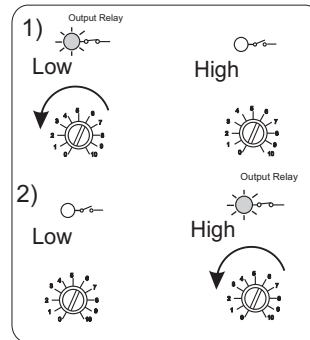
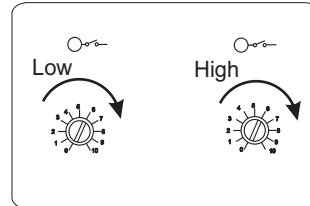

CN205 Set-Point adjustment.

CN205 controller has 5 outputs Relay (SPDT). To adjust, make sure the outputs are not actuated (statement made by the LED's),if necessary turn the potentiometers clockwise (Fig.2).

- 1) Fill the tank until the desired set-point.
- 2) Choose the desire output(from 1 to 5).
- 3)Turn the respective potentiometer defined for the set-point counter-clockwise until the LED indicator turn-on.

Set the rest of the outputs following the same procedures for all.

Fig.2

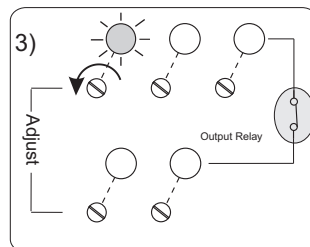
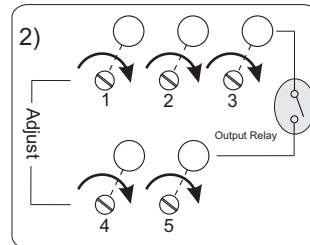

Handling

Probes:

Seal the thread with Teflon tape before installation (Fig. 1).

Fig. 1

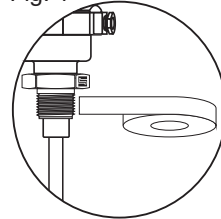

Do not turn or handle by the housing (Fig. 2).

Fig. 2

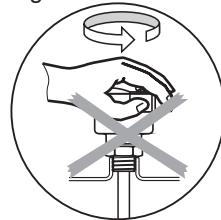

When tightening the sensor, use only use the 316S.S. hexagon fitting to achieve a seal, do not twist with the body of the sensor. (Fig. 3)

Fig. 3

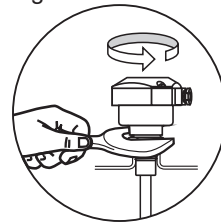

The probe should not be dropped or suffer any impact or fall that could damage the electronics or the coating of the probe (Fig. 4 and 5).

Fig. 4

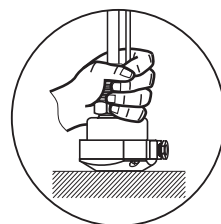

Periodic visual inspection of the probe is required to check for corrosion or deposit build-up. If deposits are found, clean the sensor to ensure optimum performance.

Fig. 5

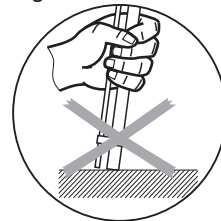

Care should be taken when handling and installing probes with coated rods to avoid scratching them. Scratching the coating could interfere with the probe performance.

When cleaning the rod use a soft brush or any other similar object.

Technical Specifications

SC120 A1

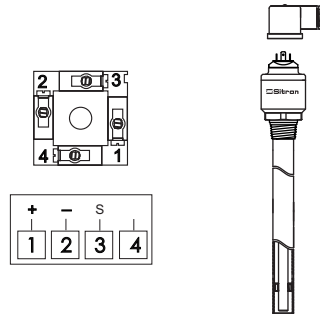

Application	Continuous Level Measurement for Liquids and Solids
Current Consumption	22mA max
Adjustment	--
Sensitivity Range	0 to 10.000pF
Electrical Connection	Plug DIN 43650
Process Connection	3/4" to 1 1/2" BSP or NPT Flange or Sanitary Connections
Wetted Parts	316 Stainless Steel, PTFE
Enclosure Material	316 Stainless Steel
Max Pressure	290 PSI (20 Bar)
Operating Temperature	-10 to 80°C
Class Protection	IP 65 (IEC 60529)

Technical Specification

SC120 G1 Housing

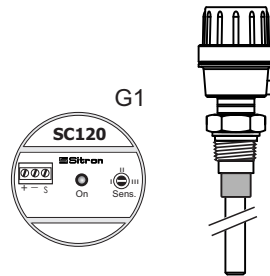

Application	Continuous Level Measurement for Liquids and Solids
Current Consumption	22mA max
Adjustment	Sensibility. (1,2,3 stages)
Sensitivity Range	0 to 10.000pF
Frequency Oscillation	400 kHz
Accuracy	0.5%
Repeatability	+/- 1mm
Electrical Connection	½" NPT, M12 Conector or Cable Gland
Process Connection	3/4" to 1 1/2" BSP or NPT Flange or Sanitary Connections
Wetted Parts	316 Stainless Steel, PTFE
Enclosure Material	Aluminum
Max Pressure	290 PSI (20 Bar)
Operating Temperature	-10 to 80°C
Class Protection	IP 65 (IEC 60529)

Technical Specifications

Controller CN202

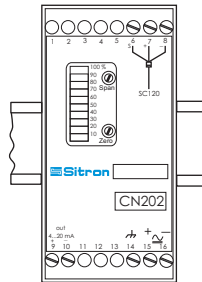

Application	Continuous Level Measurement for Liquids and Solids
Operating Voltage	24Vdc (10%) 85...264 Vac (50/60Hz)
Current Consumption	4 VA
Adjustment	Zero & Span
Output	4...20mA
Accuracy	Max error 0.5%
Repeatability	+/- 1mm
Level Indication	Bargraph
Dimensions	L x W x H (111mm x 43mm x 83.5mm)
Involucre	ABS (Thermoplastic Resistant)
Fixation	2 screws & DIN rail(35mm)
Operating Temperature	-10 to 60°C
Class Protection	IP 40 (IEC 60529)

Technical Especifications

Controller CN200

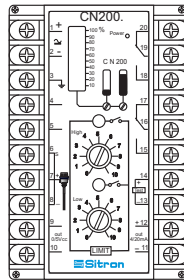

Application	Continuous Level Measurement for Liquids and Solids
Operating Voltage	DC: 24Vdc (10%) AC: 85...264 Vac (50/60Hz)
Current Consumption	4 VA
Adjustment	Zero & Span and 2 Set-Point Control
Output	4...20mA & 2 Relay Output (SPDT 5A-250Vac)
Accuracy	Max error 0.5%
Repeatability	+/- 1mm
Level Indication	Bargraph
Dimensions	L x W x H (109mm x 75mm x 110mm)
Involucre	ABS (Thermoplastic Resistant)
Fixation	2 screws & DIN Trail(35mm)
Operating Temperature	-10 to 60°C
Class Protection	IP 40 (IEC 60529)

Technical Specification

Controller CN205

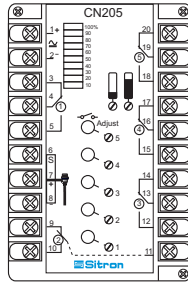

Application	Continuous Level Measurement for Liquids and Solids
Operating Voltage	DC: 24Vdc (10%) AC: 85...264 Vac (50/60Hz)
Current Consumption	5 VA
Adjustment	5 Set-Point Control
Output	5 Relay's Output (SPDT)
Accuracy	Max error 0.5%
Repeatability	+/- 1mm
Level Indication	Bargraph
Involucre	ABS (Thermoplastic Resistant)
Dimensions	L x W x H (109mm x 75mm x 110mm)
Fixation	2 screws & DIN Trail(35mm)
Operating Temperature	-10 to 60°C
Class Protection	IP 40 (IEC 60529)

Trouble Shooting

Fault	Cause	Solution
No signal	No power supply	Verify power supply
	Inadaquate connection	Verify the polarity of the power supply
Signal over 22mA	Probable short circuit	Verify that the rod is coated for conductive mediums
	Sensitivity to high	Adjust sensibility again
Signal Fluctuating	Lack of signal from referance rod	Verify the grounding
Signal under 20mA	Sensitivity to low	Adjust sensibility again
Lack of linearity	Reference is incorrect	Add a Reference
		Sheath the rod
	Coating on the rod is damaged	Send back for repair

Ordering Information

MODEL	
SC120	
SCT120	
SIZE	
4	3/4"
5	1"
6	1 1/2"
7	2"
9	3"
Q	4"
X	OTHER
PROCESS CONNECTION TYPE	
B	BSP
D	FLANGE ANSI 150# CARBON STEEL PAINTED
E	FLANGE ANSI 150# 316 SS
F	FLANGE ANSI 150# PVC
K	FLANGE ANSI 150# 304 SS
N	NPT
T	TRI-CLAMP
X	OTHER-SPECIFY
COATING	
S	NONE
E	EPOXY (UP TO 120°)
H	HALLAR COATED
T	PTFE TUBED (UP TO 120C)
T	PTFE TUBED (CABLE)
X	OTHER-SPECIFY
M	PTFE TUBED FOR HIGH TEMP. (UP TO 200C)
TYPE OF ROD OR CABLE	
R	RIGID ROD 1/2"(12.7mm) or 5/8"(16mm)-316SS
RR	RIGID ROD+REFERENCE ROD-1/2"(12.7mm) or 1/4"(6.3mm)-316SS
MR	STEEL CABLE-6.0mm + REFERENCE CABLE
C	ROD (1/2") and SHEATH 316SS
M	STEEL CABLE-6.0mm + REFERENCE CABLE
INSERTION LENGTH	
L	SPECIFY
HOUSING	
A1	316 SS STAINLESS STEEL
G1	SMALL ALUMINIUM
ELECTRICAL CONNECTION	
1	1/2" BSP
2	CABLE GLAND W/ 1/2" BSP
4	3/4" BSP
5	CABLE GLAND W/ 3/4" BSP
6	1/2" NPT
7	CABLE GLAND W/ 1/2" NPT
9	3/4" NPT
C	CABLE GLAND W/ 3/4" NPT
P	METAL CABLE GLAND M20
Y	STEEL CABLE GLAND M16
OPTIONS	
MT	Medium Temp - 50mm 316SS Neck (80-120°C)
AT	High Temp - 100mm 316SS Neck (80-150°C)
ST	316 SS TAG
0	NONE

Terms & Conditions

Sitron's TERMS & CONDITIONS

Design: Sitron reserves the right to make any alterations or changes necessary to improve the Products, correct defects or to make the Products safer, without prior notice or consent by Buyer.

Pricing: All stipulated amounts shall be in US dollars and all prices quoted are valid for thirty (30) days from date of offer, unless otherwise stated.

Safety and Instructions: The Buyer ensures that it and all its representatives and agents will observe all safety and technical instructions in Sitron's operating manuals, catalogs or other directions or instructions (either written or verbal).

Delivery and Freight: All goods are sold FOB point of shipment, Brasil. Transportation to the destination is the Buyer's responsibility and Buyer alone shall bear the cost of freight, optional or other shipping requirements, and or insurance. Sitron shall not be liable for loss or damage to the Products after said Products are delivered to or received by the shipper/carrier, and all risk of damage or loss shall immediately pass to Buyer.

Receiving, unloading and storing of Products will be the responsibility of the Buyer.

Buyer also accepts that courier may choose to return Products to Sitron if any local taxes or duties are not paid by Buyer at point of delivery. Buyer must make any and all claims for corrections or deductions within ten days of the delivery of the Products.

Shipment Delays: Sitron has no control over the length of time shipments may be held at customs, etc. For this reason, Sitron commits only to a "shipment date", not a "delivery date". Buyer shall not hold Sitron liable for claims resulting from delay in shipment except in cases where these terms are accepted in writing by Sitron. Acceptance of delivery of Products by Buyer shall constitute a waiver of all claims for delay.

Partial Deliveries: While Sitron strives to deliver all orders on time and complete, Sitron reserves the right to make partial deliveries when necessary.

Changes: Any changes initiated by the Buyer which affects the products specifications; quantities ordered; delivery schedule; method of shipment or packing; or delivery location, must be made in writing and signed by both parties.

In this case, Sitron reserves the right to adjust the pricing and or delivery of the order, which will be agreed to by both parties before further work is performed on the order. Any such requests will be priced according to the scope of changes and the status of the current order. Customer must sign and return or acknowledge approval of drawings along with any Purchase Order. If approval drawings are not returned with order, the delivery date may be held or pushed back until Customer has acknowledged approval.

Cancellation: Any cancellation of the Contract by the Buyer shall be effective only if made in writing and accepted, in writing by the Sitron. In such a case, Sitron is entitled to reasonable cancellation charges including but not limited to labor, material and other related expenses.

Terms & Conditions

Termination Fee Schedule:

Order entered but not released for manufacturing	10%
Order in any stage of production	75%
Order complete and ready for shipment	100%

Warranty: Sitron warrants its product against manufacturing defects in material and workmanship, when installed in applications approved by Sitron, for a period of one year from the date of original shipment, unless otherwise stated in writing by Sitron.

Sitron is not responsible for damage to Sitron's Products or other equipment or products because of improper installation or misapplication of the Products by Buyer. Installation or startup of Sitron's equipment must be performed under the guidelines set forth in Sitron's instruction manuals, wiring diagrams, etc., or performed under the direct supervision of Sitron's field technicians or Sitron's authorized Sales Representatives, in order to be covered by Sitron's warranty.

Sitron shall be under no liability in respect to any defect from fair wear and tear, willful damage, negligence, abnormal working conditions, failure to follow Sitron's instructions (whether written or verbal), misuse, modification or alteration or attempted repair of the Goods without Sitron's approval.

Sitron shall not be liable under the above warranty (or any other warranty, condition or guarantee) if the total price for the Products or the payment of Services rendered has not been paid by the due date for payment.

The Buyer must make all tools, resources or personnel available to help Sitron to diagnose the defect without any back charge. In absence of Buyer's cooperation in this regard, there shall be no liability under the above Warranty.

Sitron's liability under this warranty shall be limited to repair or replacement at Sitron's option of such defective Products, FOB factory, upon proof of defect satisfactory to Sitron. Warranty does not include transport.

Return Goods: No goods may be returned without Sitron's permission and an RMA number. Sitron assumes no responsibility for return shipments made without permission. In issuing credit for such shipments, Sitron reserves the right to charge a restocking fee dependent on Sitron's ability to recondition and resell the returned equipment.

Insurance: The responsibility for insuring the Goods after the risk in them has passed to the Buyer shall be that of the Buyer.

Confidential Information: All drawings, specifications, and technical information provided by either Buyer or Sitron shall be treated as confidential and shall not be disclosed to anyone other than those who require it as part of the fulfillment of the order. Buyer agrees that the designs and/or any other related material provided are and remain Sitron's exclusive property and that the Buyer acquires no right, title or interest to this intellectual property, whether in whole or in part.

Errors: Sitron reserves the right to correct all typographical or clerical errors or omissions, in its prices or specifications.



rev_01_2015

Sitron - Brasil
R. Baronesa de Itu, 83
São Paulo - SP - 01231-001
T: (5511) 3825-2111
F: (5511) 3825-2171

Sitron - USA
1800 Prime Place
Hauppauge, NY 11788
PH: 516-935-8001
FX: 800-516-1656

www.sitron.com
BRASIL: vendas@sitron.com
USA / Other Countries: info@sitron.com